

Manganese Lithium Coin Batteries (ML series): Individual Specifications

ML614S

■ Dimensions(mm)

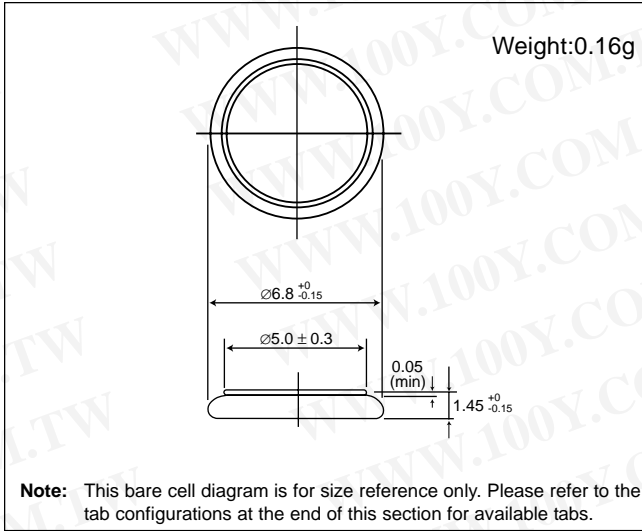

■ Specification

Nominal voltage (V)	3
Nominal capacity (mAh)	3.4
Continuous standard load (mA)	0.01
Operating temperature (C)	-20 ~ +60

■ Discharge characteristics

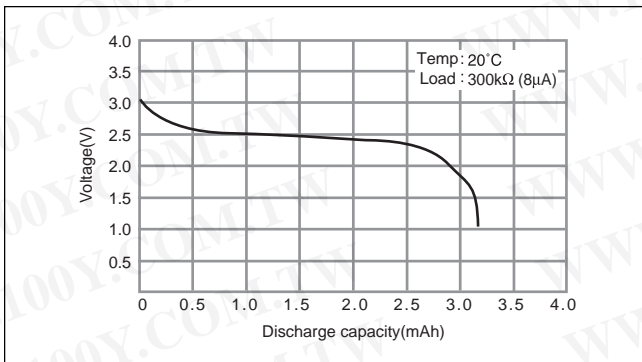

■ Consumption current vs. Duration time

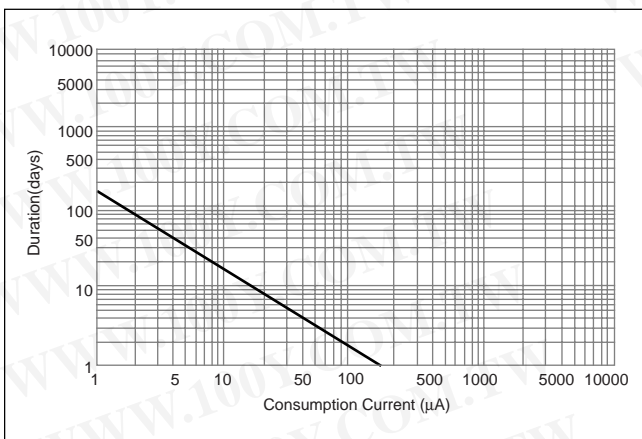

ML621S

■ Dimensions(mm)

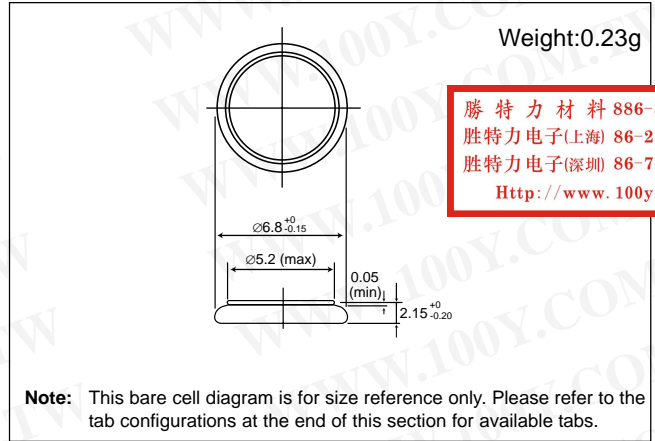

勝特力材料 886-3-5753170
 勝特力电子(上海) 86-21-34970699
 勝特力电子(深圳) 86-755-83298787
[Http://www.100y.com.tw](http://www.100y.com.tw)

■ Specification

Nominal voltage (V)	3
Nominal capacity (mAh)	5
Continuous standard load (mA)	0.01
Operating temperature (C)	-20 ~ +60

■ Discharge characteristics

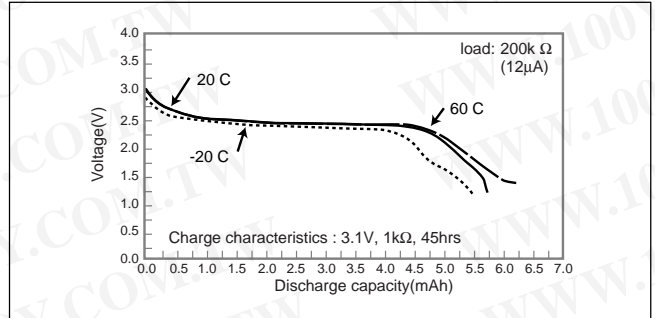

■ Charge characteristics

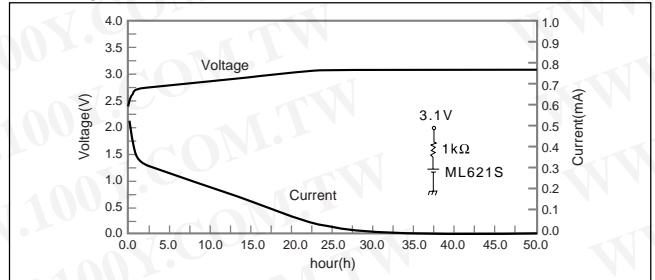

■ Consumption current vs. Duration time

